

A close-up photograph of a brass fitting, likely a flowmeter or sensor, with a black handle. The brass has a polished, golden-yellow finish. The fitting is shown from an angled perspective, looking into its internal bore. The background is a dark, out-of-focus grey.

DIGMESA
NANO BRASS
- THE NEW
ORIGINAL
LIQUID
FLOW
SENSING
SOLUTION

A close-up portrait of a man with short brown hair, wearing a dark suit jacket, a blue shirt, and a red and white striped tie. He is looking directly at the camera with a slight smile. In his right hand, he holds a small, intricate mechanical component, possibly a coffee machine part, which is highlighted by a soft light. The background is dark and out of focus.

«SMALL
IS GOOD,
NANO IS
BETTER»

Stefan Schneider
Head of Development

With this innovative reinvention of the well-proven original, DIGMESA is ready for the current and upcoming challenges in the world of professional coffee machines.

More than 30 years ago, Heinz Plüss, founder of Digmesa, was the first to introduce a flow meter to control the water flow in professional coffee machines. This product was the FH series flowmeter which built the foundation for a successful international company specialized in flow measurement for liquids, with many products to follow.

Nozzle	Flow Range	pulses / liter without pulse divider	pulses / liter with pulse divider
1.0 mm	~ 0.035 - 0.4 l/min	~ 39'900	~ 2'494
1.2 mm	~ 0.05 - 0.5 l/min	~ 31'100	~ 1'944
1.4 mm	~ 0.06 - 0.7 l/min	~ 23'040	~ 1'440

Nozzle	Flow Range	Frequency range without pulse divider	Frequency range with pulse divider
1.0 mm	~ 0.035 - 0.4 l/min	~ 23 - 270 Hz	~ 1.4 - 17 Hz
1.2 mm	~ 0.05 - 0.5 l/min	~ 26 - 270 Hz	~ 1.6 - 17 Hz
1.4 mm	~ 0.06 - 0.7 l/min	~ 23 - 270 Hz	~ 1.45 - 17 Hz

Accuracy

+ / - 2% (of reading)

Pressure and Temperature

max. Pressure: 20 bar

max. Temperature: 100° C

Electrical Connection

Output Signal: open collector NPN pulse

Power Supply: 2.8 - 24.0 VDC

Material

Housing: Brass (low-lead brass, uncoated) (CW510L)

Nozzle: PEEK

Turbine: PVDF 1M (wetted)

Approvals

NSF, LFGB (EU 1935/2004, EU 10/2011), CE

Today, Digimesa engineers have taken a new approach to the same problem. They took his original design and evolved it to the next level with the goal in mind to develop a very cost-effective sensor device without sacrificing the quality of the proven FH.

With this core foundation, these engineers developed the new nano brass. With its solid and yet very compact lead-free brass housing and sealed electronics, this device is perfectly tailored to fulfill the highest demands of the professional coffee machine manufacturers.

Process Connection

2x G 1/8" BSP f/f STD

El. Connection

3-pin 2.8 x 0.5 mm (valve connector compatible) STD

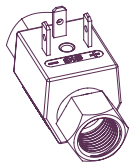

3.96 mm straight header (MTA - 156) •

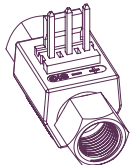

Cable with Connector (Molex mini Fit, cable length <26 cm) •

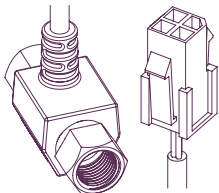

Cable with Connector (AMPMODU II, cable length <24 cm) •

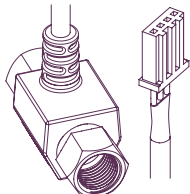

Electrical Options

Resistor 1.2 kOhm •

Pulse divider 1:16 STD

Without pulse divider 1:16 •

- compact and lightweight design
- freely selectable mounting position
- low-lead brass, uncoated
- cost effective
- high accuracy and reliability
- easy and cost-effective shipping and storage
- food approved (NSF 169, LFGB (EU 1935/2004, 10 / 2011))
- Swiss quality precision manufactured

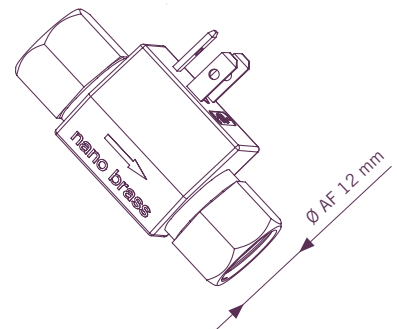
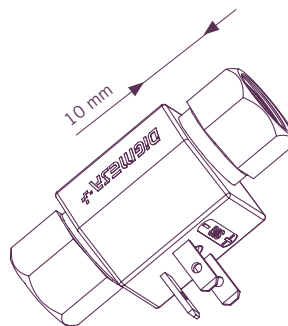
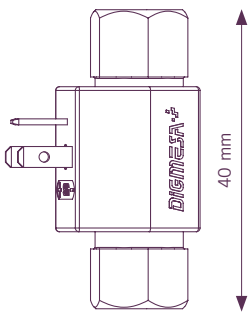
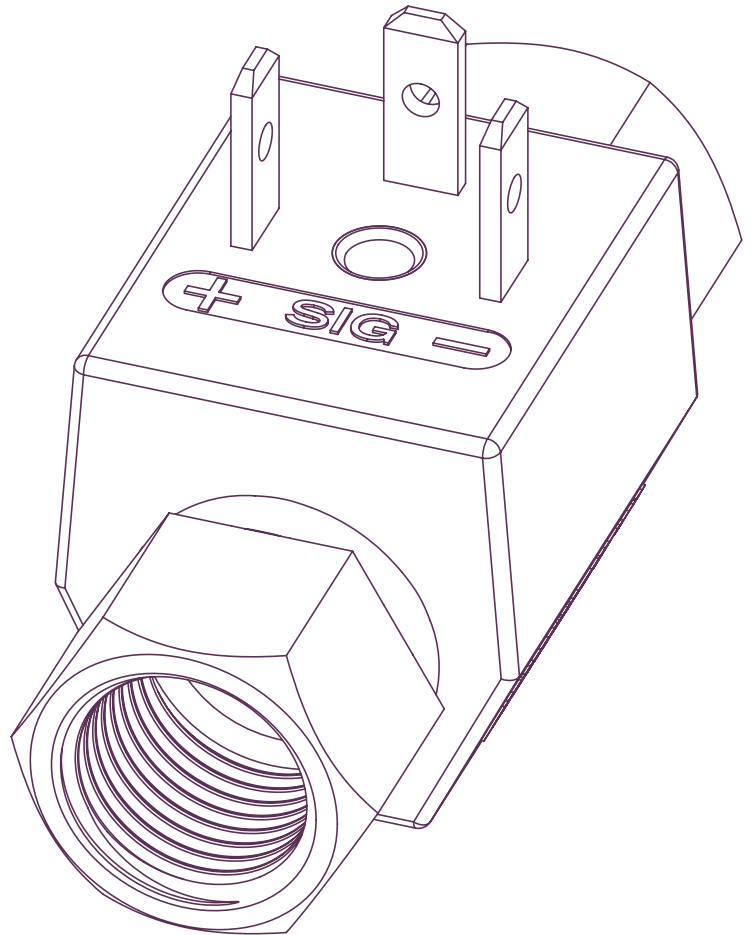

DIGMESA INTERNATIONAL LTD.
BACHSTRASSE 3
6362 STANSSTAD
SWITZERLAND

WWW.DIGMESA.COM
INFO@DIGMESA.COM

All measurements have been taken under ideal laboratory conditions.