



BV-C2905 SWIR Line Scan camera

The BV-C2905 is a compact and robust line scan camera and employs the sensor having the sensitivity on SWIR (Short Wave Infrared) range from 950nm to 1700nm.



BV-C2905 is a SWIR line scan camera and uses an InGaAs sensor which is 25 micron pixel size and its sensitivity is from 950nm to 1700nm. The interface is supported either Camera Link or Gigabit Ethernet complying with GigE Vision® and GenICam™. The lens mount is C mount and lenses larger than 1-inch can be used. BV-C2905 can inspect dust, scratch or foreign substances which a visible length camera cannot catch or the conditions inside the package.

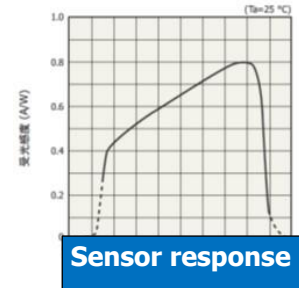

Item	BV-C2905-GE	BV-C2905-CL
Line sensor	Effective pixel:512 pixels, Pixel size: 25μm x 25μm, Effective image length: 12.8mm	
Wave length range	950nm to 1700nm	
Synchronization	Internal / External trigger	
Pixel clock frequency	5 MHz	
Line frequency	8.1KHz (Maximum)	
Exposure time	Variable range:100μs to 10ms	
Conversion efficiency	Standard sensitivity mode:160nV/e- High Sensitivity mode: 930nV/e-	
S/N	58dB (Gain=0dB)	
Gain	0 dB ~ +12 dB	
Black level	0 LSB ~ 127 LSB variable (10bit utput)	
Main functions	External trigger, Compensation(DSNU, PRNU, Blemishes, Shading), Field up-date	
Video output	Mono 8-bit, 10-bit, 12-bit	
Operating mode	Shutter mode (Internal / External trigger)	
Trigger input	Hirose 6P	Hirose 6P or Camera Link(CC1 ~CC4)
Communication I/F	Gigabit Ethernet (1000BASE-T)	Camera Link
Lens nmount	1-inch C mount	
Power consumption	DC12V ± 1V, 4W	
Operating temperature	-5°C ~ +40°C / 20% ~ 80% (Non-condensing)	
Storage temperature	-25°C ~ +65°C / 20% ~ 80% (Non-condensing)	
Dimensions (WxHxD)	58 x 58 x 60mm (excluding mount and protrusion)	
Weight	290 g	300g
Regulations	ROHS, CE	
Camera Control	SDK-TransFlyer (Aval Data)	General purpose RS-232C tool

- Specifications are subject to change without a prior notice
- This product is in the scope of Export Trade Control Order and required the export license for exportation.

Optional unit

SWIR C mount lens



Bluevision provides SWIR C mount lenses for BV-C2905 as showing the following table. The image size for these lenses is 15mm in horizontal direction.

Model	Weight	F value	WS (work size) (Note: Reference value)		
			Magnification at M.O.D	WS (mm)	Used camera
BV-L1020-SWIR-C	760 g	2.8	x -0.071	180	BV-C2900 BV-C2905
BV-L1024-SWIR-C	630 g		x -0.081	158	
BV-L1028-SWIR-C	650 g		x -0.1	130	
BV-L1035-SWIR-C	630 g		x -0.128	100	
BV-L1050-SWIR-C	410 g		x -0.167	78	
BV-L1105-SWIR-C	1110 g		x -0.37	35	

BVA-AC06P Power supply unit



The BVA-AC06P is an AC adaptor exclusively used for cameras having Hirose 6P connector as the power input. Input voltage: 100V~240V, 50Hz/60Hz

Output: DC12V±3%, 1A

Weight: 120g

Outlook dimensions

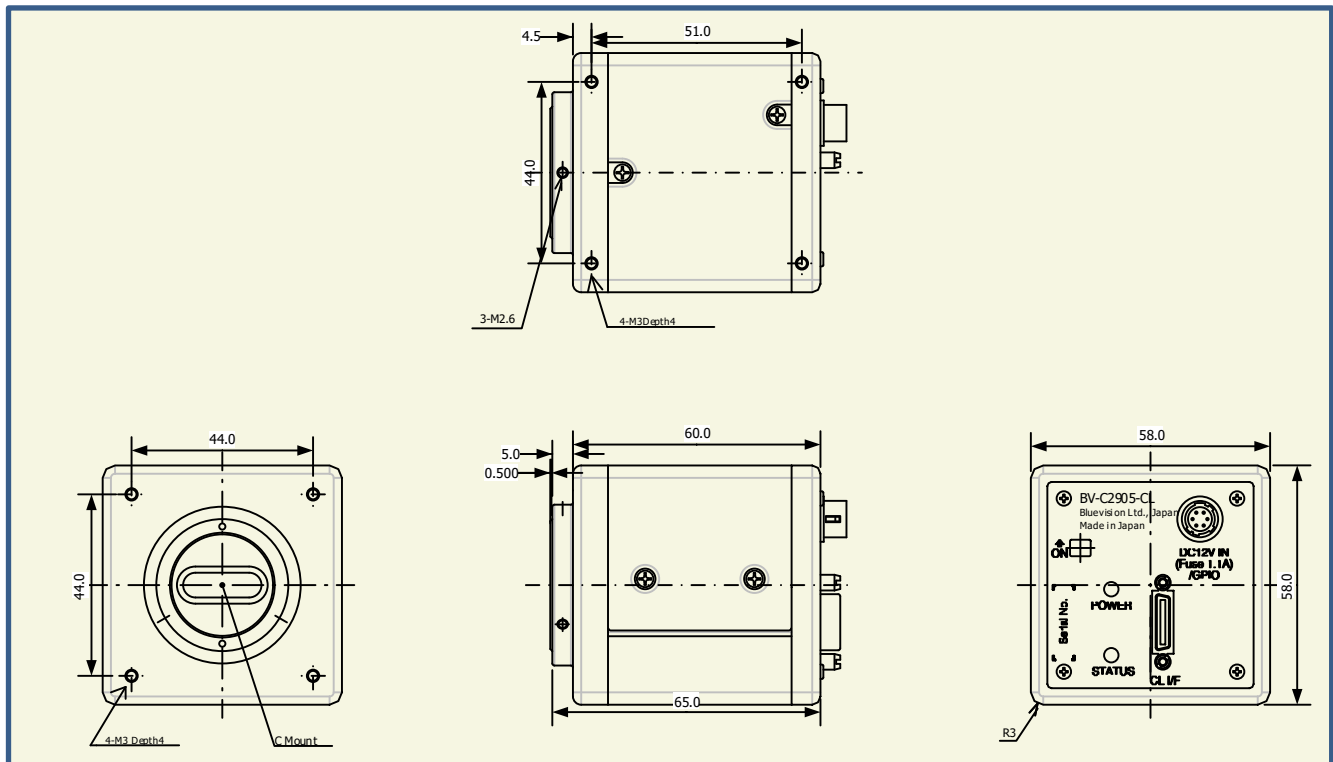

Bluevision Ltd., Japan

Klingenberg building 303

1-13-12 Shin-Yokohama, Kohoku-ku, Yokohama 222-0033 Kanagawa, Japan

TEL:045-471-4595/FAX:045-471-4598

E-mail: sales@bluevision.jp