

CURRENT OUTPUT TYPE VORTEX FLOW METER **KARUMAN ACE**

Type **SLK**

- Karman vortex fluid flow meter of wetted part PFA.
- Highly durable and precise Karman vortex flow meter having a simple structure free of movable parts.
- Type SLK - * * 33 is provided with LED display + current output + open collector output.

CE mark applicable (available upon request)
UL listed (available upon request)

COMMON SPECIFICATIONS

Power supply voltage : 12 to 24V. DC

Current consumption : Less than 100mA

Allowable working fluid temperature : 0 to 90°C
(Type SIK-053 : 0 to 60°C)

Working ambient temperature : 0 to 50°C

Working ambient humidity : Less than 95%RH

Accuracy : ±2%FS

Responsibility : Approx. 1 second

Applicable fluids : Pure water, chemical liquids and other various fluids
(On condition that these liquids do not corrode any material of main body)

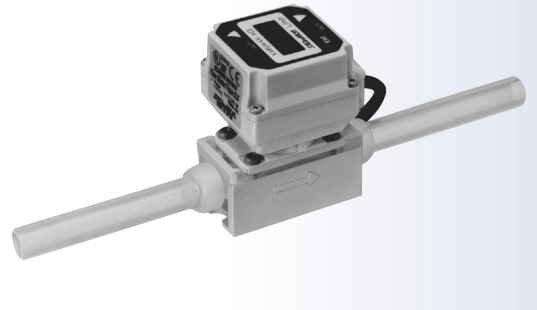

SPECIFICATIONS

Catalog No.						Measurable Flow Range (L/min)	Kinematic Viscosity (mm ² /s)	Max. Operating Pressure (MPa)	Wt. (kg)
Type	Connection Size	Main Body Material	Output	Connection Style	Packing Material				
SLK-	05	3 (PFA)	3 (4 to 20mA open collector x 2 w/display)	A (Finallock)	X (None)	0.4 to 3.5	1	1	0.22
	08					1 to 10	1.2 or less		
	10					2.5 (2) to 20	1.5 or less		
	15					4 (3) to 40	2.5 or less		
	20					10 (8) to 90	4 or less		
	05		2 (4 to 20mA without display)	T (Tube)		0.4 to 3.5	1	1	0.23
	08					1 to 10	1.2 or less		
	10					2.5 (2) to 20	1.5 or less		
	15					4 (3) to 40	2.5 or less		
	20					10 (8) to 90	4 or less		

- Numeric values in () in the measuring flow range show those of water (1mm²/s at 25°C). 05 type is guaranteed only when dynamic viscosity of fluids is 1mm²/s.
- Finallock joint is manufactured by Kurashiki Boseki Co., and nuts and phenol are attached to it.

OPERATION

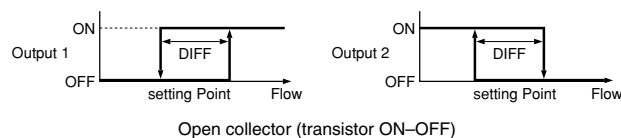

DESCRIPTION OF INDICATOR

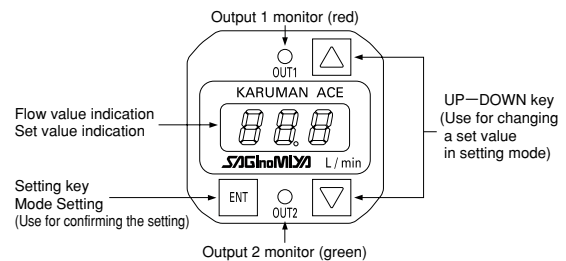

WIRING DIAGRAM

(Type SLK - * * 32 comprises neither output 1 nor output 2.)

In case of direct drive of load

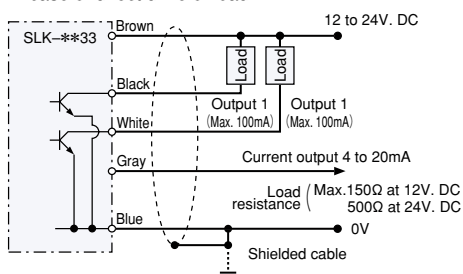

In case of control by voltage output

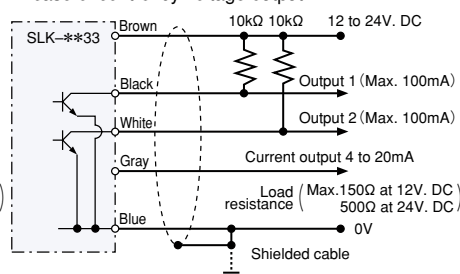

FLOW RATE

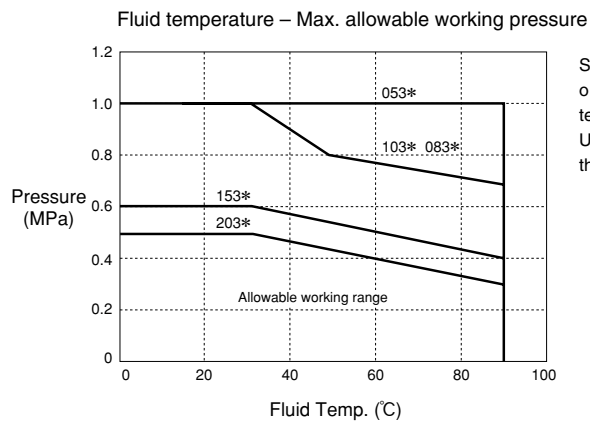
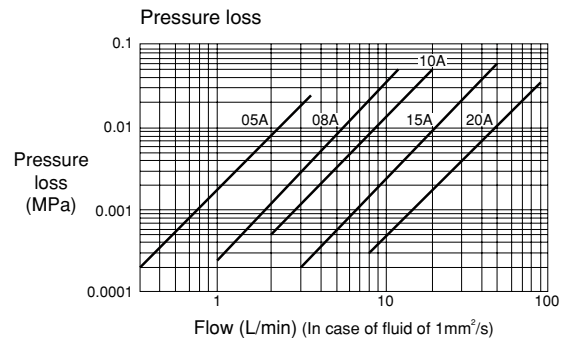
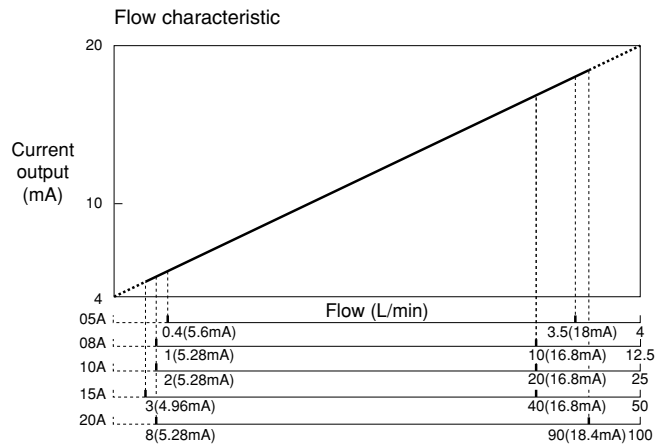

Since the main body is made of resin, the maximum operating pressure changes according to the fluid temperature and diameter. Use the unit within the allowable working range shown in the left figure.

DIMENSIONS

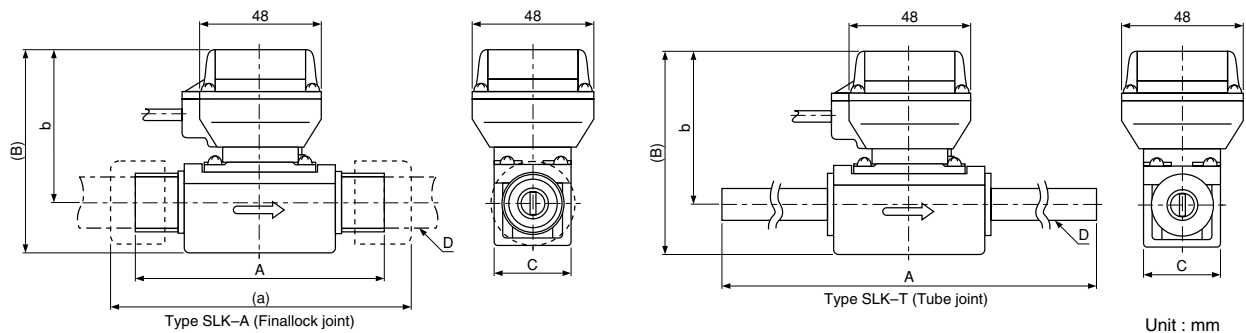

Catalog No.	Finallock joint					Tube joint				
	SLK-									
Size (mm)	0533AX	0833AX	1033AX	1533AX	2033AX	0533TX	0833TX	1033TX	1533TX	2033TX
A	85	100		130		230			280	300
a	105	120		121	156	-	-		-	-
b	57	59		61	70	57	59		61	70
B	72	76		79	93	68	76		79	93
C	30	30		30	40	30	30		30	40
D	3/8	1/2		3/4	1	3/8	1/2		3/4	1